

# Hydrostorm Pool & Spa Pumps

**WATERCO**

Water, the Liquid of Life

Delivers extra power and higher performance for larger pools

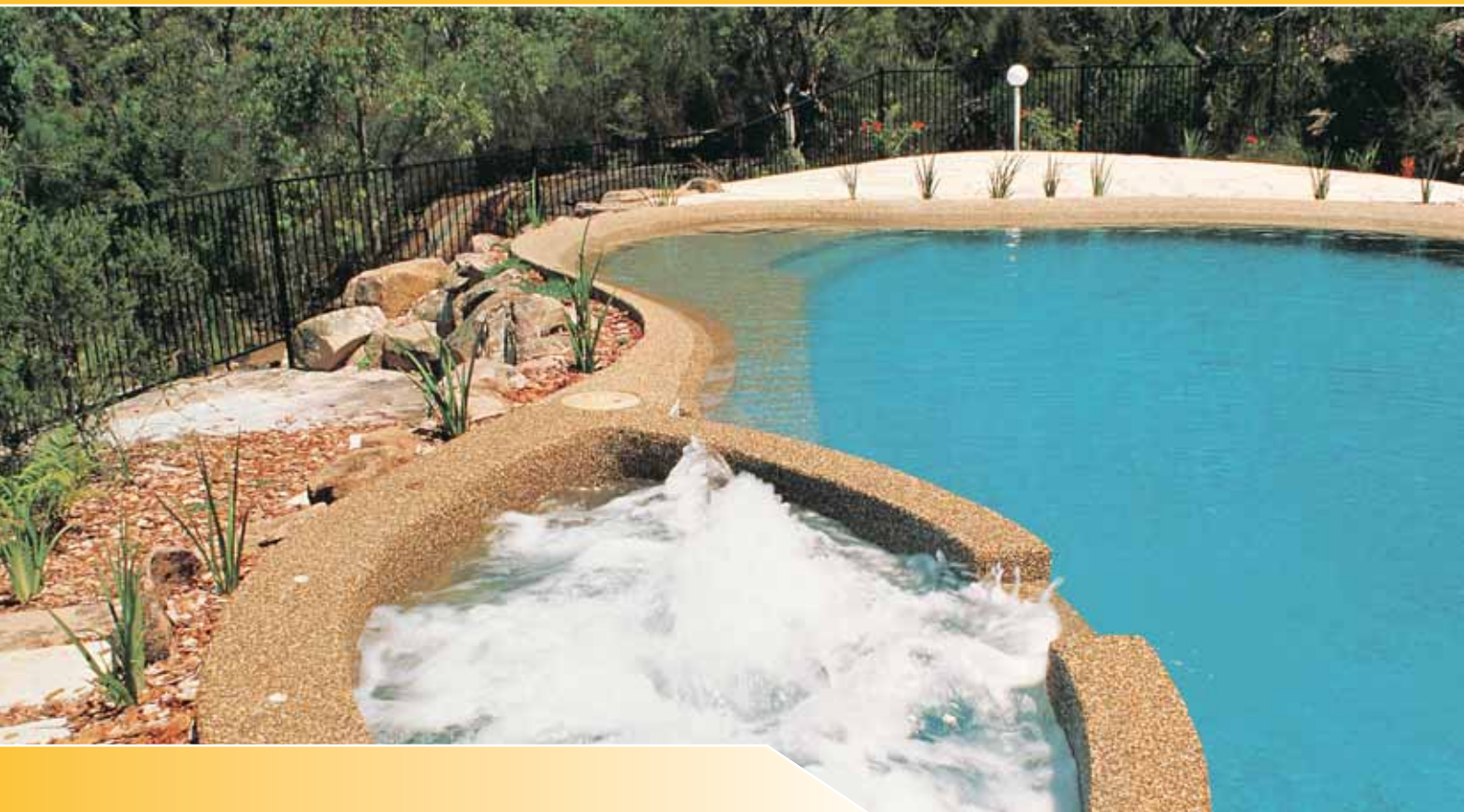

The Hydrostorm is designed to have all the extra power you need to cope with modern day swimming pool designs which can include other ancillary systems like heating, in-floor cleaning, fountains, vacuum cleaning and swim jets.

# Hydrostorm Pool & Spa Pumps

**WATERCO**  
Water, the Liquid of Life

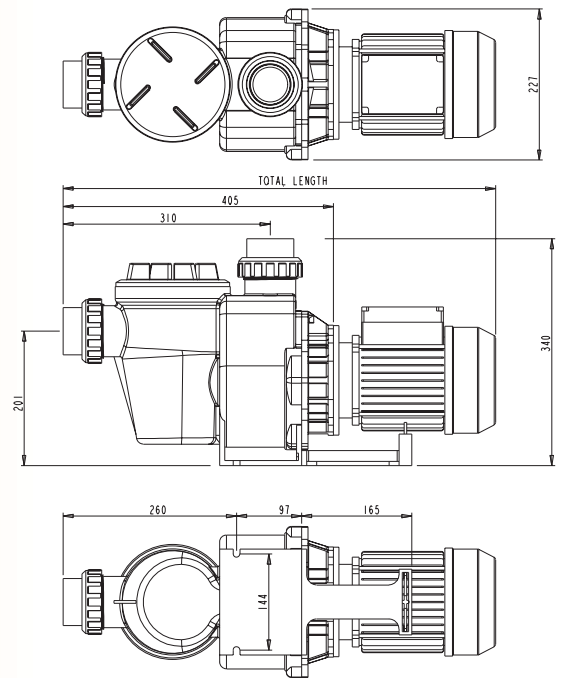
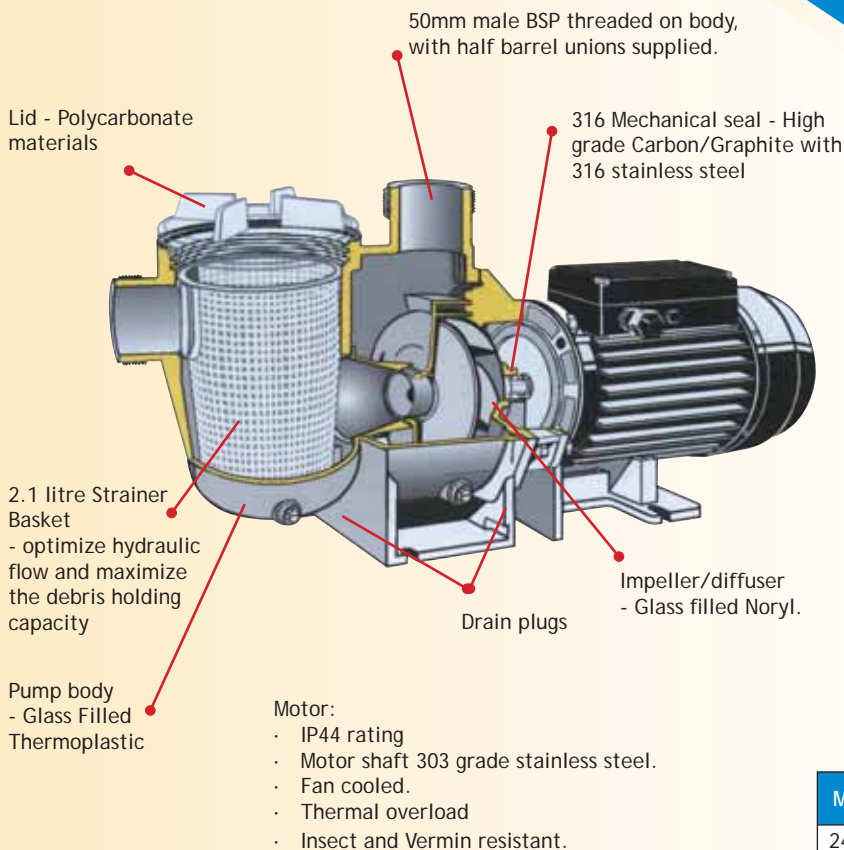

Model	PUMP	HP	KW	Amps	Phase	Total Length	Motor Frame
244100	100	1.00	0.91	4.00	1	646	80
244125	125	1.25	1.08	4.80	1	646	80
244150	150	1.50	1.31	6.00	1	646	80
244200	200	2.00	1.46	6.60	1	646	80

Phase	Volts	Cycle	RPM	Pump rating
1	220 - 240	50	2860	IPX4

## Efficient Impeller and Diffuser Design

The pump's impeller and diffuser design maximizes the hydraulic output of the pump while minimizing turbulence. The pump's efficient hydraulic performance shortens run times and reduces energy consumption leading to lower operating costs.

## Engineered Durability

The pump body is manufactured utilising state of the art engineering plastic moulding with a single piece strainer pot and volute for extra strength. And a high grade 316 stainless steel mechanical seal is incorporated for extra protection against corrosion. e.g. chlorinated water, ozone, iodine, Baquacil, bromine and salt water.

## Warranty

Waterco pumps are covered by a comprehensive 2 year Warranty (1 year on mechanical seal) for residential installations and a 1 year Warranty for commercial installations.

### OFFICES - AUSTRALIA

NSW (Head Office)  
Sydney  
Tel: +61 2 9898 8600  
Fax: +61 2 9898 1877  
QLD - Brisbane  
Tel: +61 7 3299 9900  
Fax: +61 7 3299 9911  
VIC/TAS - Melbourne  
Tel: +61 3 9879 5141  
Fax: +61 3 9879 5143  
WA - Perth  
Tel: +61 8 9273 1900  
Fax: +61 8 9273 1999

SA/NT - Adelaide  
Tel: +61 8 8244 6000  
Fax: +61 8 8244 6011  
ACT Distribution  
Tel: +61 2 6280 6476  
Fax: +61 2 6239 1395

### OFFICES - OVERSEAS

Waterco USA Inc  
Phoenix, AZ  
Tel: +1 623 434 4703  
Fax: +1 623 434 4704  
Augusta, GA  
Tel: +1 706 793 7291  
Fax: +1 706 790 5688

Waterco Canada Inc  
Tel: +450 796 4333  
Fax: +450 796 4365  
Waterco (Europe) Ltd  
Tel: +44 (0) 1795 521 733  
Fax: +44 (0) 1795 522 085  
Waterco (NZ) Limited  
Tel: +64 9 525 7570  
Fax: +64 9 525 6580  
Waterco (Guangzhou) Ltd  
Tel: +8620 8335 1107  
Fax: +8620 8335 1114

Waterco (M) Sdn. Bhd.  
Tel: +60 3 6250 8169  
Fax: +60 3 6250 8175

[www.waterco.com](http://www.waterco.com)

## Hydrostorm Pump Performance Curves

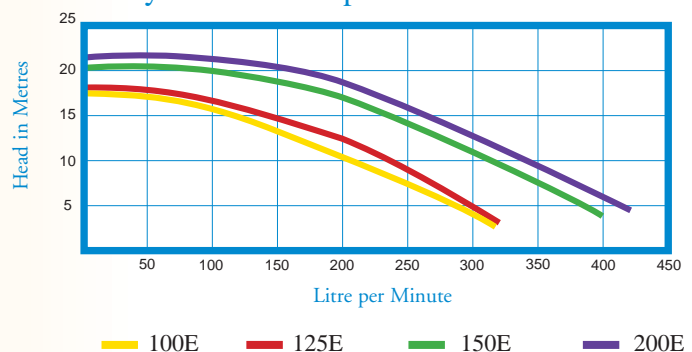

## DISTRIBUTED BY:



ZZB0568 07/05