

Supastream Pool & Spa Pumps

WATERCO
Water, the Liquid of Life

State-of-the-Art power



Supastream incorporates the latest technology in design, testing and construction to produce a reliable general purpose pump for a variety of applications.

Supastream Pool & Spa Pumps

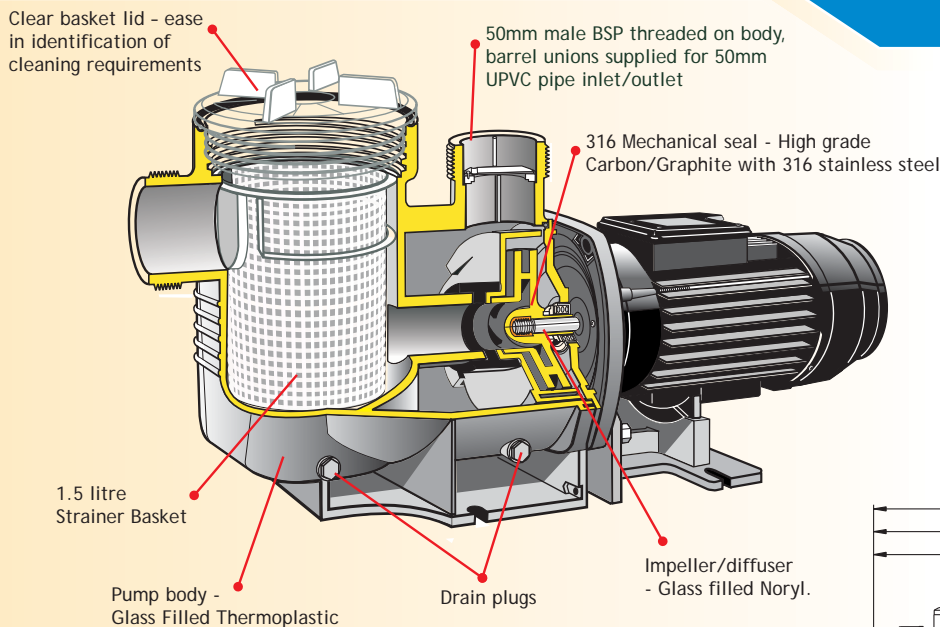

Motor:

- Motor shaft 303 grade stainless steel.
- Fan cooled.
- Thermal overload
- Insect and Vermin resistant.

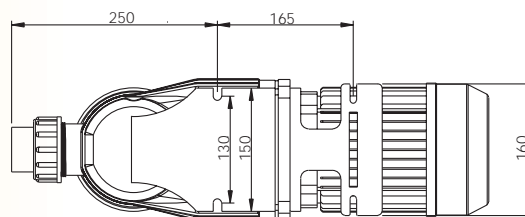
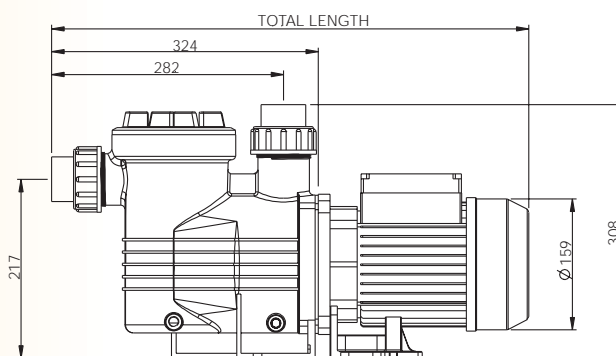

Efficient Impeller and Diffuser Design

The pump's impeller and diffuser design maximizes the hydraulic output of the pump while minimizing turbulence. The pump's efficient hydraulic performance shortens run times and reduces energy consumption leading to lower operating costs.

Engineered Durability

The pump body is manufactured utilising state of the art engineering plastic moulding with a single piece strainer pot and volute for extra strength. And a high grade 316 stainless steel mechanical seal is incorporated for extra protection against corrosion. e.g. chlorinated water, ozone, iodine, Baquacil, bromine and salt water.

Warranty

Waterco pumps are covered by a comprehensive 2 year warranty for residential installations and a comprehensive 1 year warranty for commercial installations.

Supastream pump performance chart

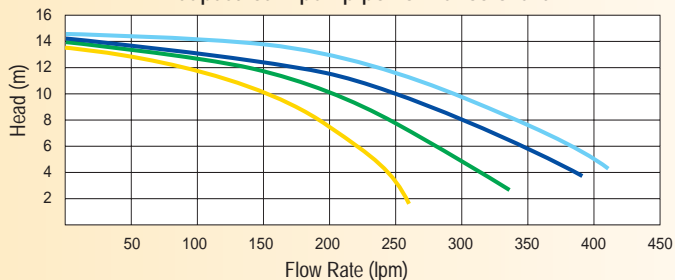

75 100 125 150

Model	Pump	HP	kW	Amps	Total Length	Motor Frame
2403075	75	0.75	0.61	2.8	536	63
2403100	100	1.00	0.82	3.6	559	71
2403125	125	1.25	0.88	3.9	559	71
2403150	150	1.50	1.09	4.9	580	80

Phase	Volts	Cycle	RPM	Pump Rating
1	220 - 240	50	2860	IPX4

OFFICES - AUSTRALIA

NSW - Sydney
(Head Office)
Tel: +61 2 9898 8600
Fax: +61 2 9898 1877
QLD - Brisbane
Tel: +61 7 3299 9900
Fax: +61 7 3299 9911
VIC/TAS - Melbourne
Tel: +61 3 9879 5141
Fax: +61 3 9879 5143
WA - Perth
Tel: +61 8 9273 1900
Fax: +61 8 9273 1999

SA/NT - Adelaide
Tel: +61 8 8244 6000
Fax: +61 8 8244 6011
ACT Distribution
Tel: +61 2 6280 6476
Fax: +61 2 6239 1395

OFFICES - OVERSEAS

Waterco USA Inc
Tel: +1 623 434 4703
Fax: +1 623 434 4704
Waterco (Europe) Limited
Tel: +44 (0) 1795 521 733
Fax: +44 (0) 1795 522 085

Waterco (NZ) Limited
Tel: +64 9 525 7570
Fax: +64 9 525 6580
Waterco (Guangzhou) Limited
Tel: +8620 8335 1107
Fax: +8620 8335 1114
Waterco (Far East) Sdn. Bhd.
Tel: +60 3 6250 8169
Fax: +60 3 6250 8175

www.waterco.com

DISTRIBUTED BY:

